

The KRONNER SIDE-KICK

A uterine manipulator Holder

for holding the Arch Koh uterine manipulator*

Instructions for use

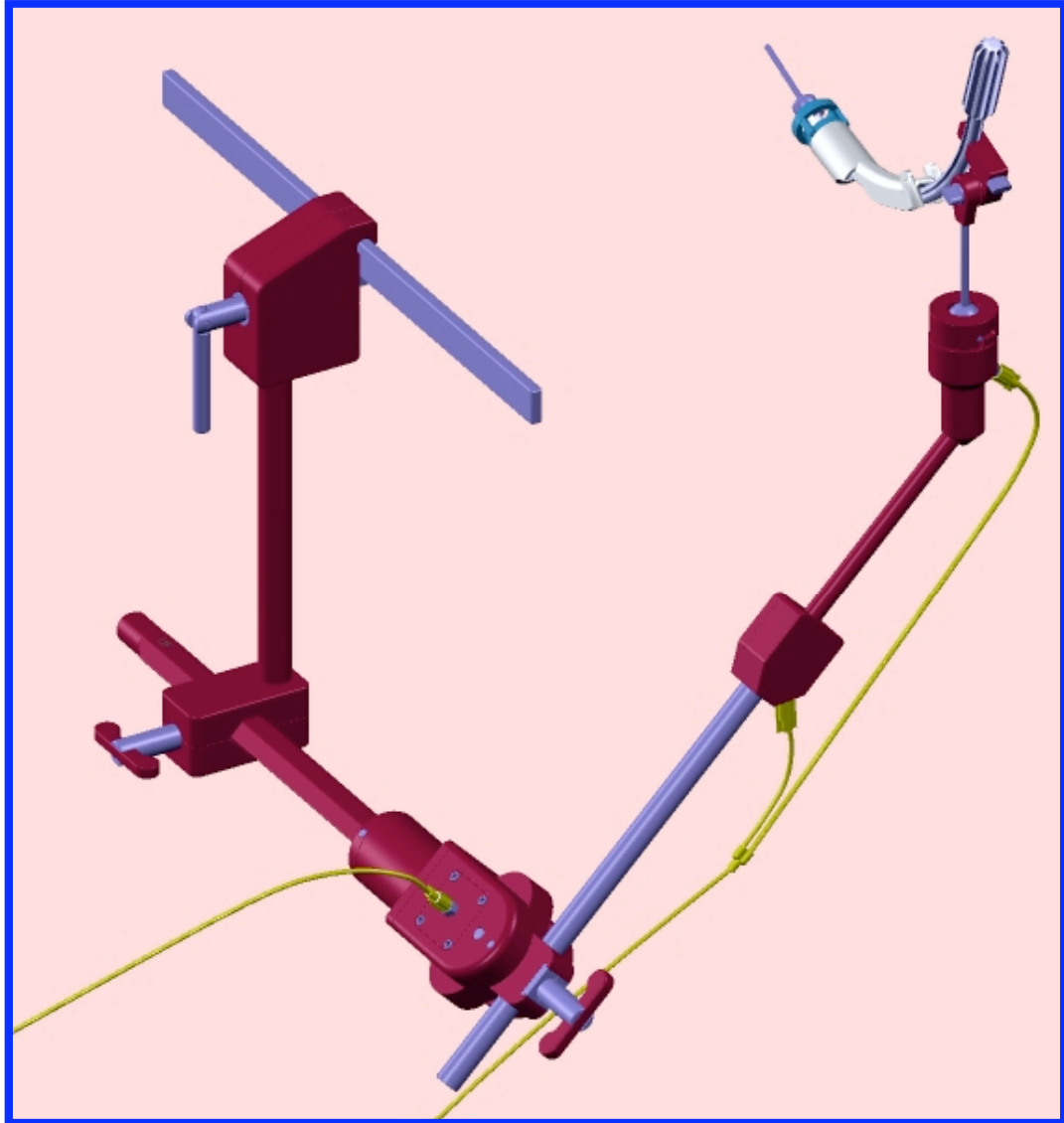

United States Patent 8,485,484.B2

* Model UMH 67, manufactured by CooperSurgical

The KRONNER SIDE-KICK A uterine manipulator Holder

Richard F. Kronner MD FACS

A description of the device and the intended use.

The **Kronner SIDE-KICK** is a uterine manipulator Holder which firmly holds the Arch Koh and other uterine manipulators during laparoscopic surgery on female pelvic organs. The Side-Kick does not interfere with re-positioning the uterus with the attached manipulator.

The Side-Kick Rail Grip is attached to either side rail of the operating table. It is placed behind the attachment for the leg stirrup.

The manipulator is inserted into the patient using standard technique, then the Side-Kick is joined to it.

With proper adapters the Side-Kick may be used with other manipulators, such as the RUMI, and the V-Care*.

A gas supply module, which is also attached to the rail of the operating table, transfers nitrogen or compressed air from the wall or a portable tank to the Side-Kick through two flexible lines. When the switch is turned off the Side-Kick joints are decompressed.

Pressing a foot pedal, that is connected to the gas supply module, releases all the Side-Kick joints for position changes. When the foot pedal is released the joints lock.

A branched gas line connects the supply module to two luers of the arm assembly. A single gas line joins the gas supply module to the main pivot.

Only the arm components and adapters are pre-vac sterilized. The disposable gas lines are supplied sterile.

Intended use:

The Kronner Side-Kick Uterine/vaginal Manipulator Holder is intended to assist the surgical staff in mounting, positioning and holding a uterine manipulator during gynecological laparoscopic surgical procedures. It is intended for use by trained operating room personnel in an operating room environment.

"Caution: Federal law restricts this device to sale by or on the order of a physician."

*See V-Care literature for required components.

Indications for use:

The Kronner Side-Kick Uterine Manipulator Holder is intended to assist the surgical staff in mounting, positioning and holding a uterine manipulator during gynecological laparoscopic surgical procedures. It is intended for use by trained operating room personnel in an operating room environment.

Contraindications:

1. Adapter unavailable for chosen manipulator
2. Table rail unreliable
3. Gas supply is unreliable or unavailable at required pressure
4. Intended surgery does not require use of a uterine or vaginal manipulator. See the uterine manipulator manufacturers' literature regarding instruction for use, indications, contraindications and safety information.

Warnings:

1. Do not use with pressure greater than 150 psi.
2. Do not detach the gas supply module from the gas supply while the manipulator is attached.
3. Do not shut off the gas supply module switch while the manipulator is attached.
4. Do not use substitute flexible gas lines.
5. Do not use if gas leaks are detected.
6. Use only the specified adapter with the chosen manipulator.
7. On older operating tables with motorized perineal rests make sure the rest is in the down position before adding the main pivot and the remainder of the assembly.
8. The gas module switch must be in the "on" position during use.
9. Do not use the sterile lines if the package is damaged or the 3 year expiration date is passed.
10. Do not attach the holder to a manipulator of a patient that is not under anesthesia or otherwise immobilized.
11. Use only nitrogen or compressed air gas.
12. In the event the Side-Kick was disassembled without turning off the gas module switch, the pneumatic joints may still be pressurized. To decompress, attach a male luer from a branched gas line with one short branch disconnected, or use a syringe with the plunger removed.
13. Do not attach the Sidekick rail grip over an attachment of the table rail to the table.
14. Attach the single gas line to the pivot and the branched line to the arm.
15. **Remove the Sidekick arm before raising the lower end of the operating table.**
16. **Do not attach a gas line to a uterine manipulator, extreme danger.**

Precautions:

1. Verify that the operating table rail is not loose.
2. Verify that the operating table end can be lowered or removed.
3. Restrain the patient from sliding on the table when the table is tilted.
4. Prevent the gas supply line from damage due to moving objects.
5. Check the uterine manipulator for defects.
6. Verify that the gas supply is steady and available at 140-150 psi.
7. Securely attach all flexible gas lines to the gas supply module and to the holder.
8. Read the instruction manual prior to use.
9. When making a patient transfer to or from the operating table to a cart with Sidekick in between remove Sidekick or protect it from the cart.
10. Always support a connected manipulator when stepping on the gas pedal.

COMPONENTS

Holder assembly

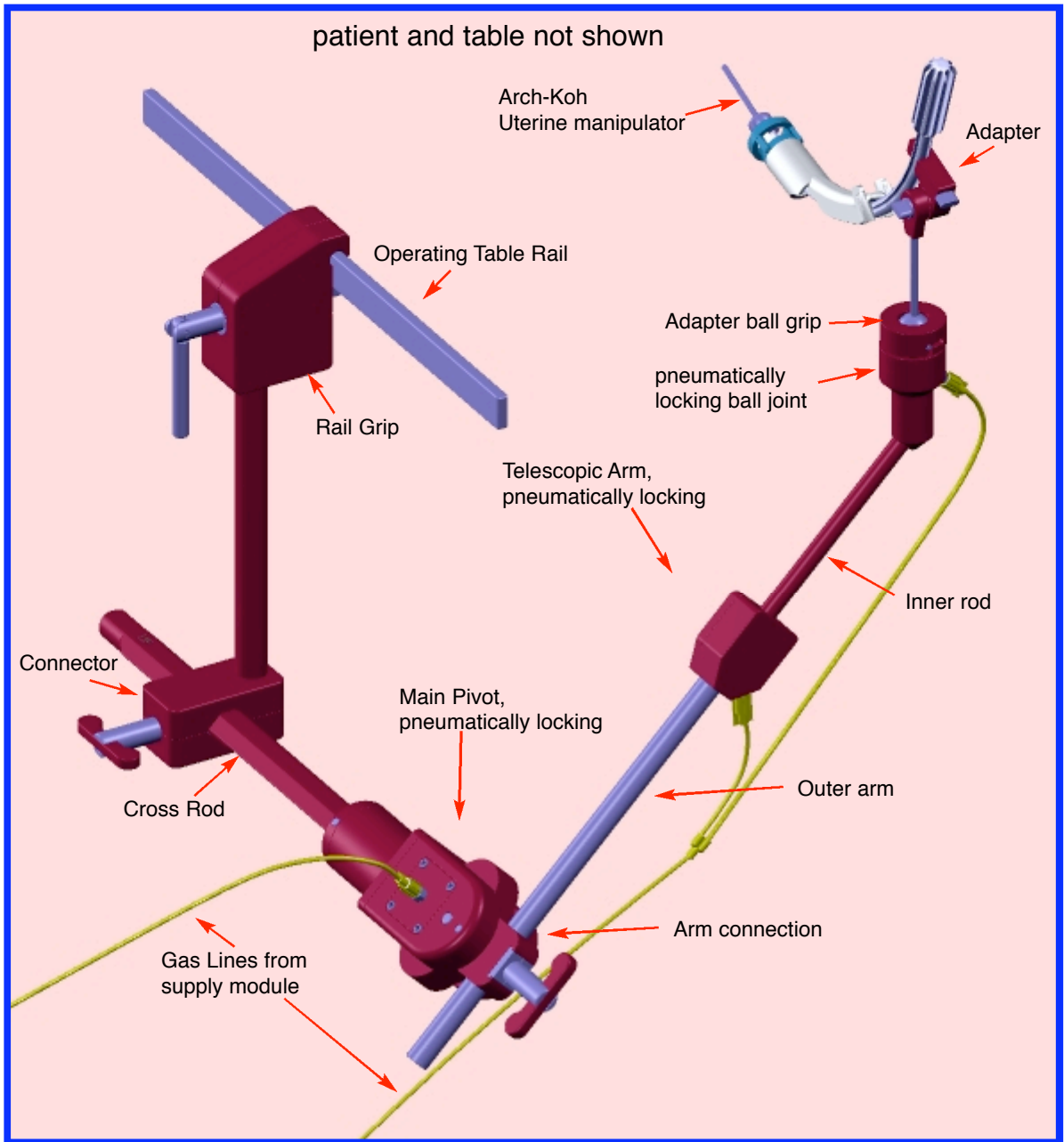

GAS LINES

supplied sterile,
shelf life 3 years,
see package label

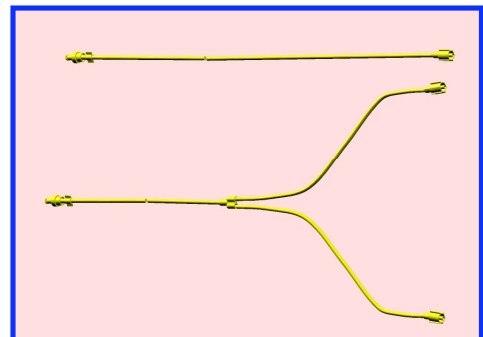

GAS SUPPLY MODULE

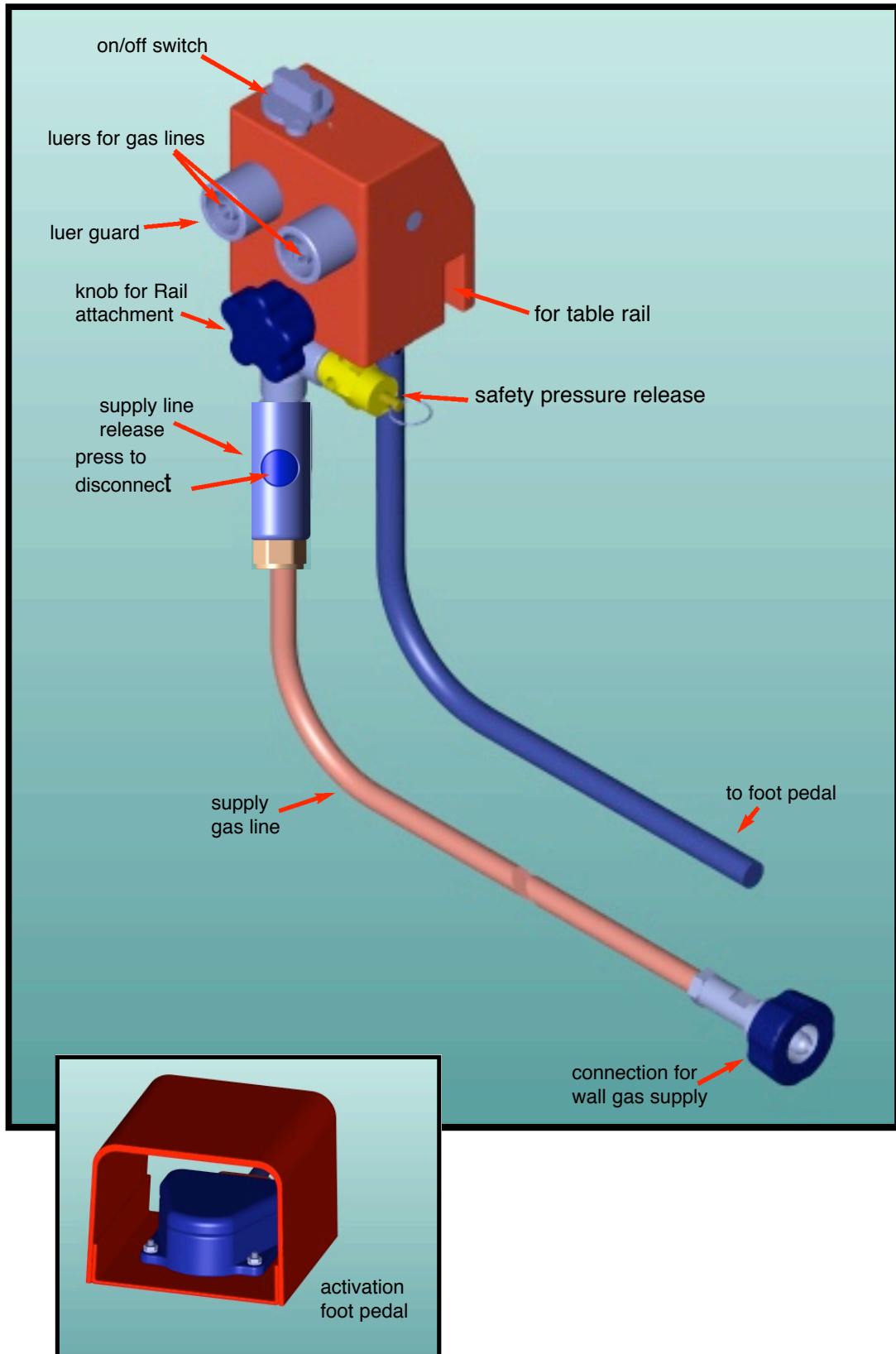

STERILIZABLE COMPONENTS

Outer arm, inner rod and uterine manipulator adapter.

Joining the inner rod to the arm.

1. After sterilization, insert the inner rod into the outer arm.
2. If resistance is met, gas pressure may not have been released after the last use. Attach a male luer from a branched gas line with one short branch disconnected, or use a syringe with the plunger removed.

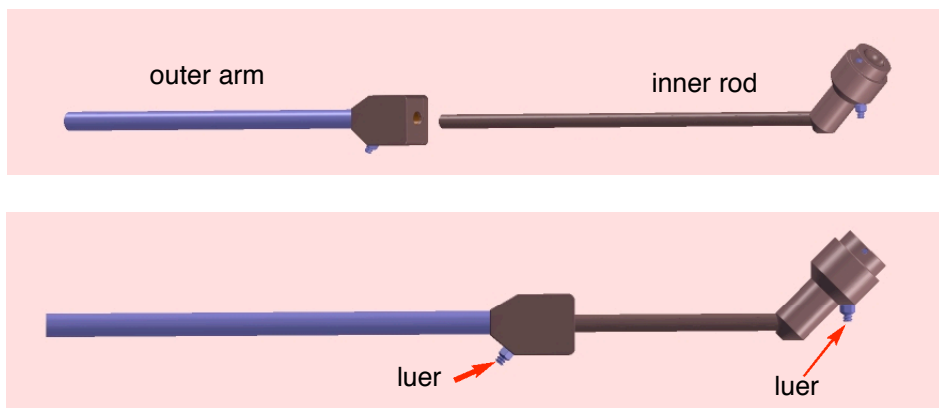

Assembling the Arch Koh adapter components

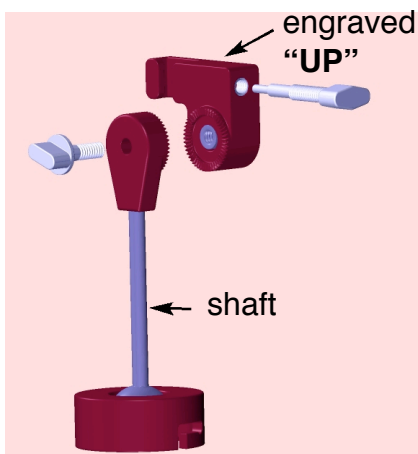

1. Join the components so the ball of the shaft is directed away from the flat surface of the grip marked "UP".



2. Position the manipulator joining screw so the adapter can be joined to the manipulator.

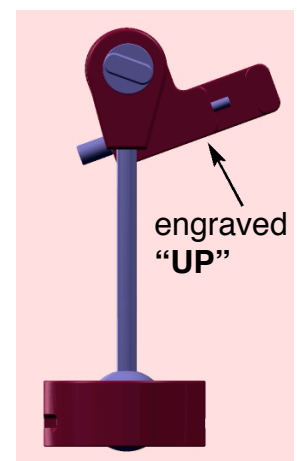

Assembled wrong

Joining the ARCH KOH to the adapter

1. Retract the joining screw so the Arch Koh can be slid into the adapter recess.

2. With the ball joint shaft directed downward, slide the Arch Koh into the recess. This connection is made just below the Arch Koh handle.

This step can be performed before or after patient insertion.

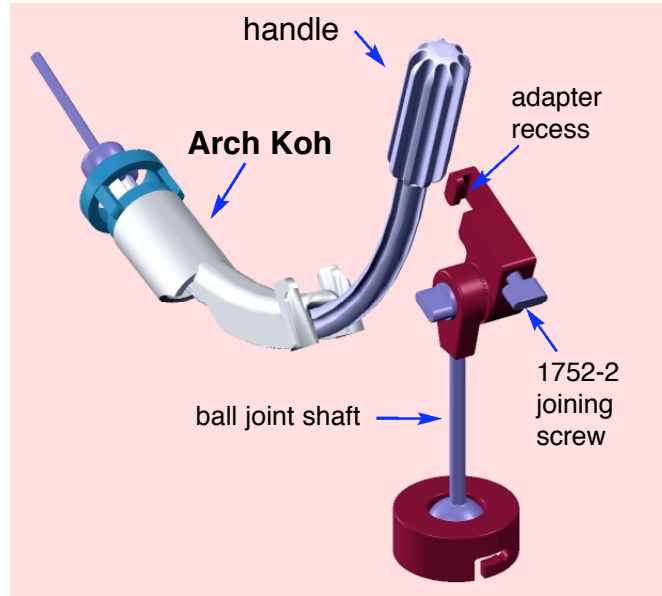

3. Tighten the joining screw.

If necessary, release the angle adjustment screw and set the joint so the ball joint shaft is directed downward. This will set the connection to the Side-Kick arm with the maximum potential range for uterine positioning.

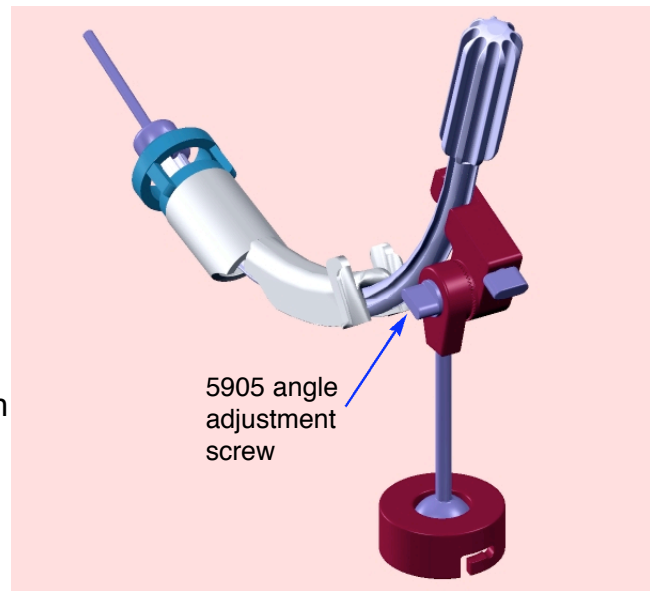

NON-STERILE COMPONENTS

Gas supply module, foot pedal assembly, main pivot, rail grip

Setting up the Gas Supply Module

1. Attach the gas supply module to the rail of the operating table at a position where the flexible gas lines will reach to the Side-Kick gas line connections. Usually this is just beside the planned position for the Side-Kick rail grip.

Whenever possible attach the gas module to the side of the table not used for patient transfer.

2. Turn off the on-off module switch. This will prevent gas from leaking from the luer connections prior to flexible gas line connection.

3. Connect the gas line to the hospital nitrogen* or compressed air supply.

4. Set the supply to 130-150 PSI.

5. Position the attached foot pedal.
(Note that it cannot be disconnected from the supply module.)

*not nitrous oxide

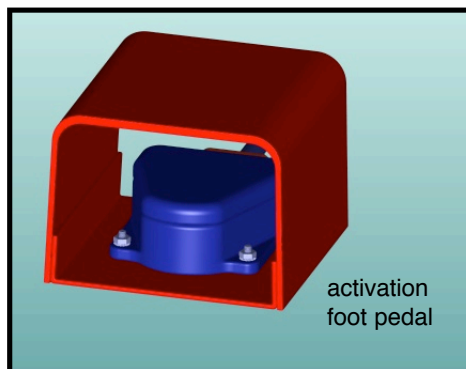
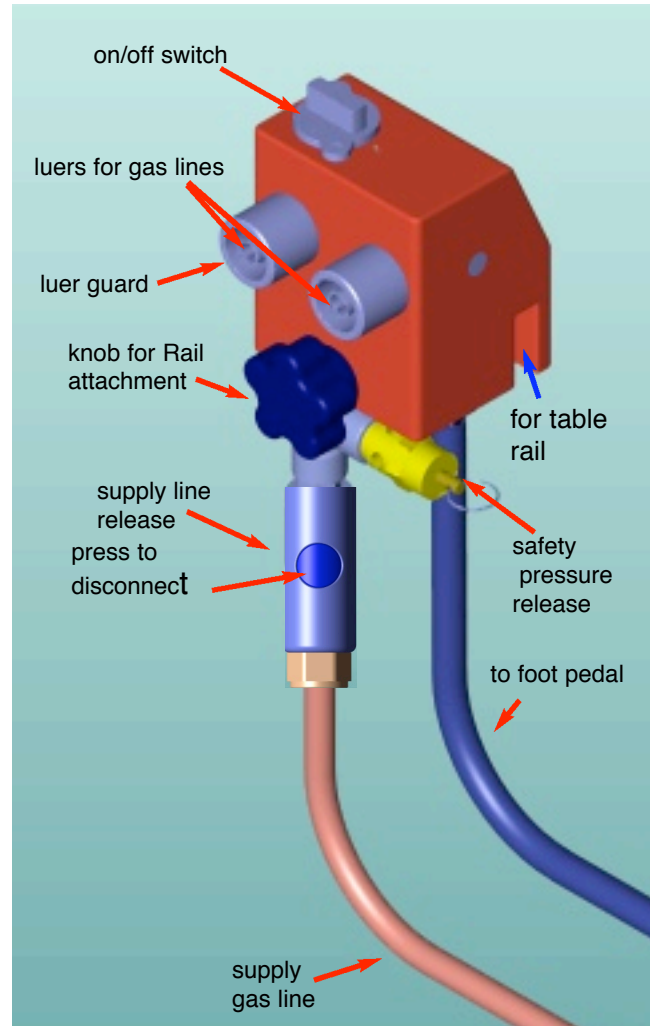

Attaching the Rail Grip assembly to the operating table rail.

The rail grip assembly can be placed on either rail behind the attachment for the leg stirrup.

1. Rotate the rail grip handle counter-clockwise until the bottom of the lower rail grip aligns with the index mark.

This setting will allow the rail grip assembly to be attached by tilting it outward.

In order to attach it without tilting, more counterclockwise rotations are required.

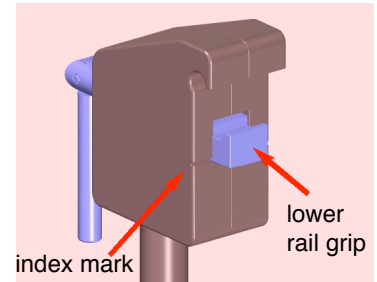

2. Select a position, on the rail, that will place the Holder arm directly below the manipulator.*

3. Tilt the assembly outward and set it on the rail. Pivot it toward the rail until the lower rail grip is below the rail.

Corrections can be made later by repositioning the main pivot assembly.*

The rail grip can be released and slid on the rail to re-position if necessary.*

*The design of the Holder allows for variability in these settings.

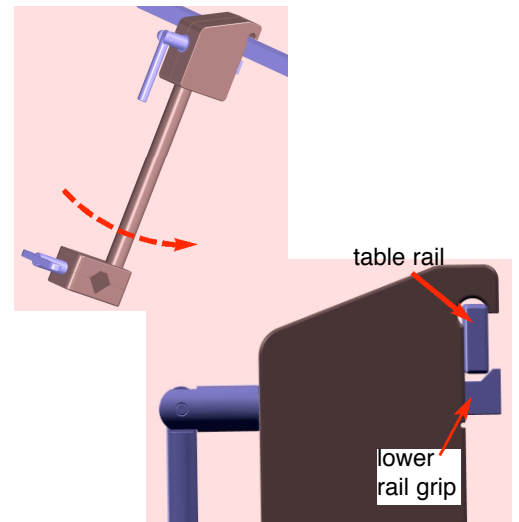

4. Rotate the handle clockwise until it is tight, approximately three full rotations.

Be sure the assembly is hanging straight downward in both planes during this step and the rail grip upper notch is touching the rail on both sides of the rail grip.

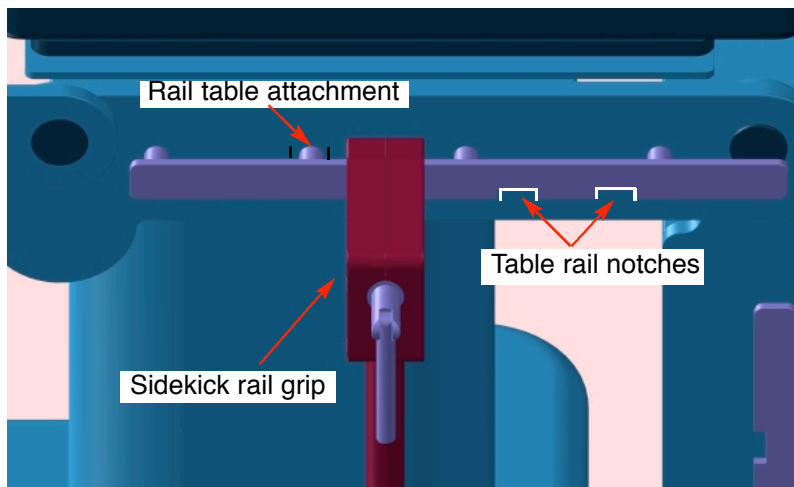
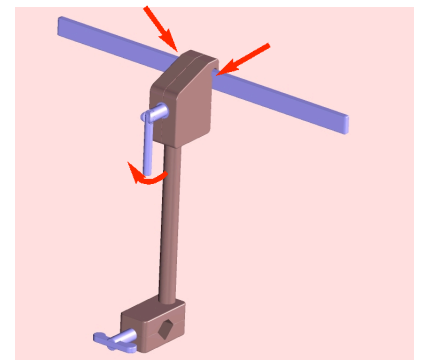

When placing the Sidekick Rail Grip onto the table rail, do not put it over the rail table attachment or a table rail notch.

Placing it in these areas could cause an unstable attachment.

Attaching the main pivot assembly to the connector of the rail grip assembly

1. Rotate the T-handle counter-clockwise to a stop to open the connection joint for the main pivot cross rod.

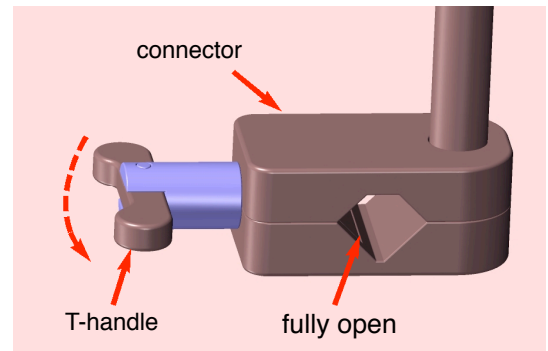

2. Position the main pivot and cross rod so "UP" is positioned upward.

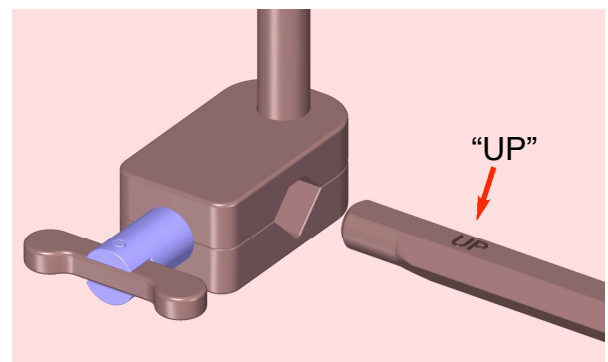

3. Insert the cross rod into the connection joint.

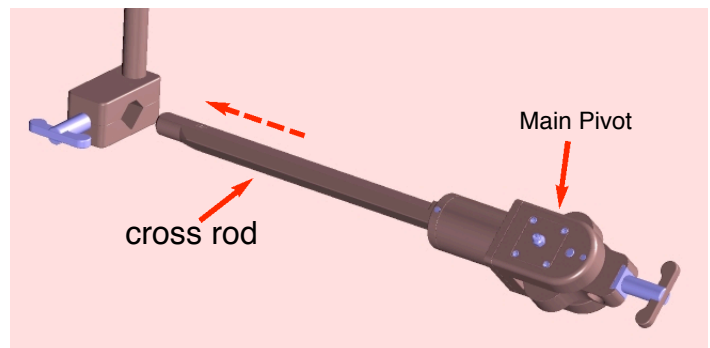

4. Slide the main pivot until the arm connection is located below the planned connection to the manipulator.

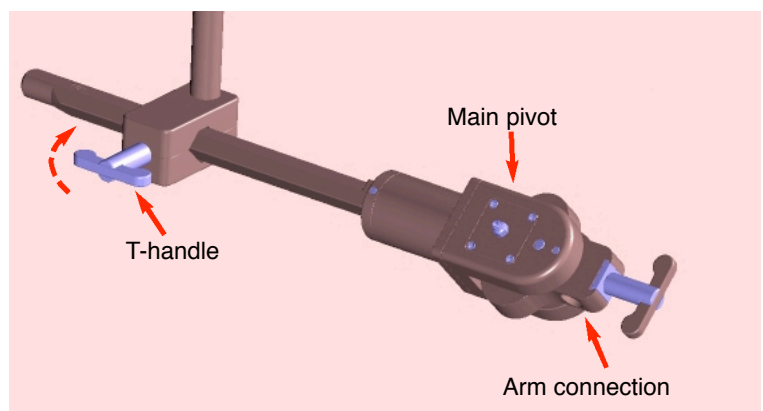

5. Firmly tighten the T-handle clockwise.

This setting can be changed later, if needed.

Attaching the arm to the main pivot

1. Rotate the main pivot handle counter-clockwise to a stop to open the attachment joint.

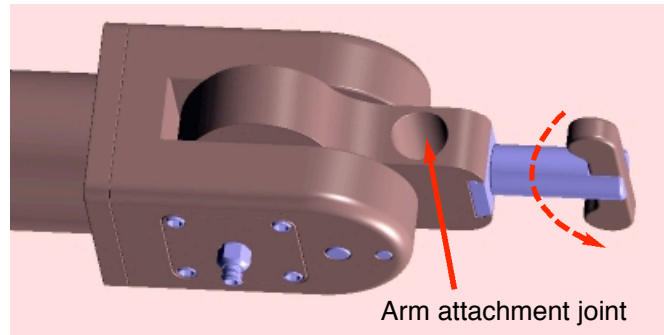

2. Insert the arm assembly into the attachment joint until the telescoping inner rod will allow for the required manipulator movement.

This setting can be changed later, if necessary.

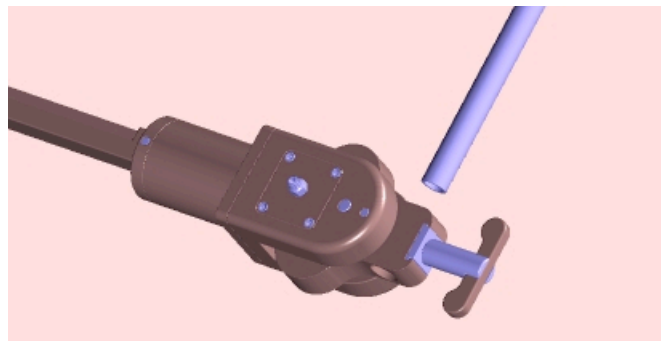

3. Tighten the main pivot handle clockwise.

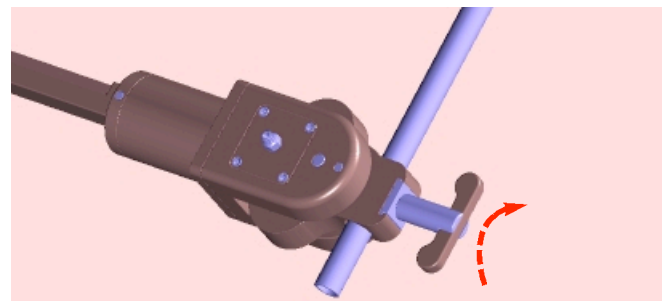

Stops prevent the arm from falling prior to pressurizing the system. Do NOT overcome these stops.

4. Lower the arm sideways to one of the stops or continue to hold it during the next steps.

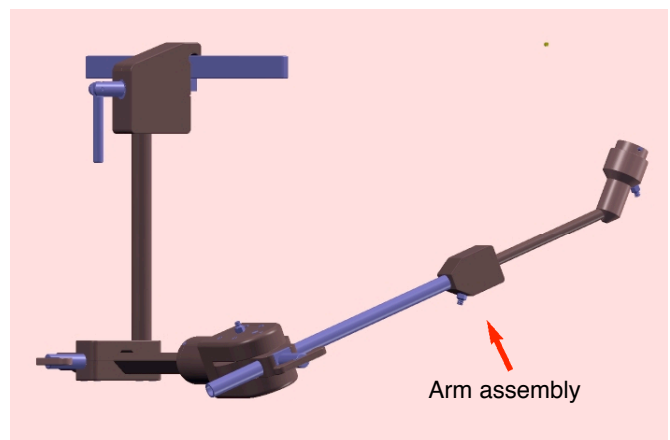

Attaching the gas lines

Warning: Do not attach a gas line to a uterine manipulator, extreme danger.

Firmly tighten all gas line luer connections.

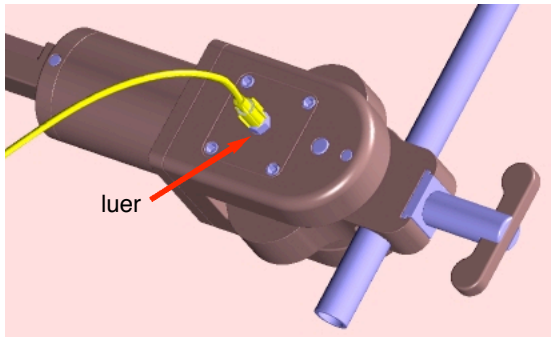

1. Connect the single gas line to the main pivot luer.

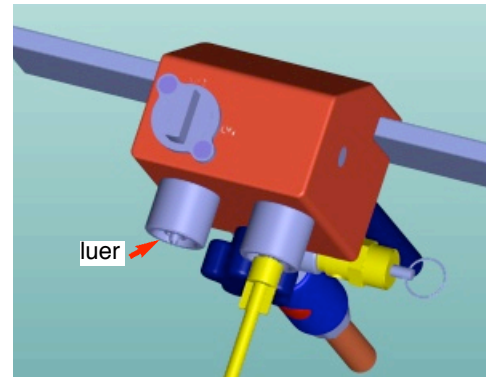

2. Connect the other end of the single gas line to one of the gas output luers of the supply module.

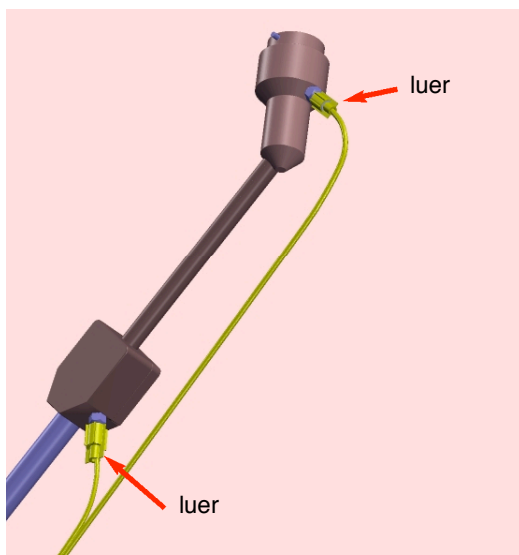

3. Connect the branched line to the two luers of the arm assembly.

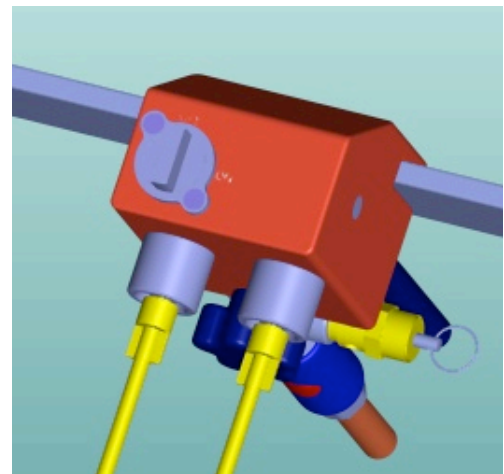

4. Connect the other end to the remaining luer of the supply module.

Note: The gas line connections to the arm may be made prior to joining the arm to the main pivot assembly.

The single gas line may be connected to the pivot and the supply module prior to arm attachment.

To avoid confusion, make these connections prior to inserting the manipulator into the patient.

Attaching the adapter with manipulator to the Holder

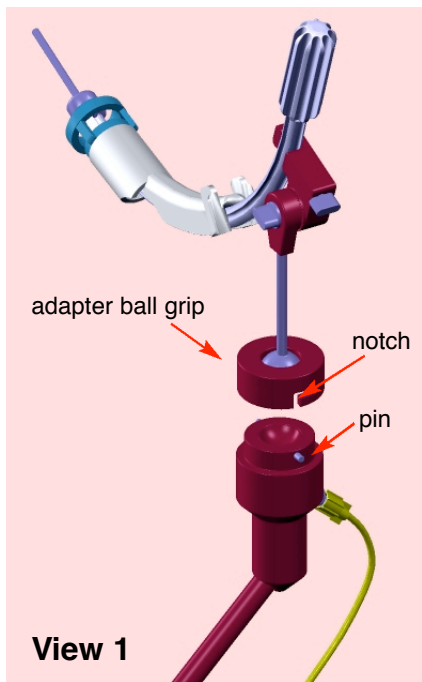

1. Insert the Arch Koh into a properly anesthetized and restrained patient.

2. Connect the adapter ball grip to the arm by sliding the two notches over the arm pins and rotating the adapter clockwise. Gas pressure must be off during this step.

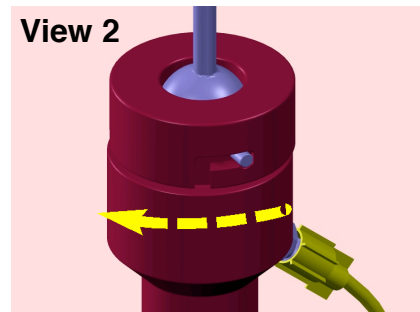

Support the arm until the gas is turned on.

Turning the gas on

1. Turn the supply module switch on.

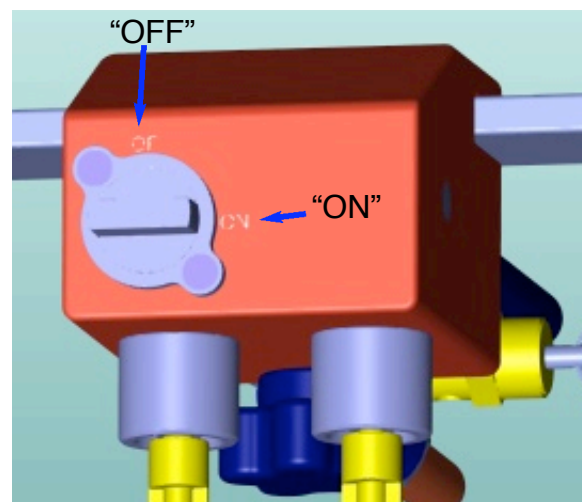

To use the Holder

1. Grasp the manipulator.
2. Press the foot pedal to re-position the attached manipulator.
3. After releasing the foot pedal, allow gas pressure to build prior to releasing the manipulator.

Problems with Sidekick

In the rare event Side-Kick interferes with required uterine manipulation or fails to hold the uterine manipulator, the uterine manipulator should be disconnected from Side-Kick. Reverse steps 1 to 3, page 6 (Joining the ARCH KOH to the adapter)

If necessary, the arm can be detached from the main pivot. Reverse steps 1 to 3 page 10. (Attaching the arm to the main pivot).

Removing Sidekick

1. Support the arm
2. Turn off the gas module switch prior to disconnecting the gas lines. This will decompress the holder joints.
3. Detach the Side-Kick adapter from the manipulator, reverse steps 1-3 page 6 entitled: **“Joining ARCH KOH to the adapter”** or detach the adapter and manipulator from the arm. Reverse step 2 page 12 entitled **“Attaching the adapter with manipulator to the Holder”**
4. Remove the manipulator following instructions from the manufacturer.
5. Disassemble Side-Kick by reversing the assembly steps.
- 6. Remove the Sidekick arm before raising the lower end of the operating table.**

Cleaning Components of the Kronner Side-Kick a uterine manipulator holder

**The rail grip, main pivot assembly,
gas supply module with foot pedal are not sterilized.**

Cleaning the sterilizable components:

Outer arm, inner rod, adapter

Manual Cleaning:

1. **Remove the inner rod from the outer arm.**
2. **Disconnect the manipulator adapter from the inner rod assembly at the ball joint and remove the manipulator joining screw from the manipulator adapter, see pg. 7.**
3. **Inspect parts for defects, such as parts not fitting together or misshapen parts. Contact Sidekick sales reps. regarding defects.**
4. **Use Enzol® enzymatic detergent**, and prepare according to the manufacture's recommendations of 1 oz. per gallon of warm tap water, (or FDA approved equivalent)
5. **Soak the outer arm, inner rod and adapter** for five minutes in the prepared solution.
6. **Maneuver movable parts to loosen trapped soil. Use a soft bristled brush (M16) to gently scrub** to remove any visible soil and actuate all moveable parts while scrubbing in order to loosen trapped soil. Use an appropriate size lumen brush (45-541) for internal channels.
7. **Repeat steps 5 and 6 two additional times for a total of three times.**
8. **Prepare a tap water bath at 38-49° C.**
9. **Agitate the assembly by hand** for a minimum of one minute in the prepared bath.
10. **Rinse the assembly** under running tap water for at least one minute.
11. **Dry the exterior of the assembly** with a clean, lint free cloth.

Sterilizing Components of the Kronner Side-Kick a uterine manipulator holder

Sterilizing the Outer arm, inner rod, and adapter:

1. Place items in the Kronner Sterilizer tray as illustrated
2. Sterilization wrap : Kimgard KC400 (or FDA approved equivalent)
3. Pre-vacuum temperature: 270 F, (132C)
4. Exposure time: 4.0 minutes
5. Drying time: 45 minutes

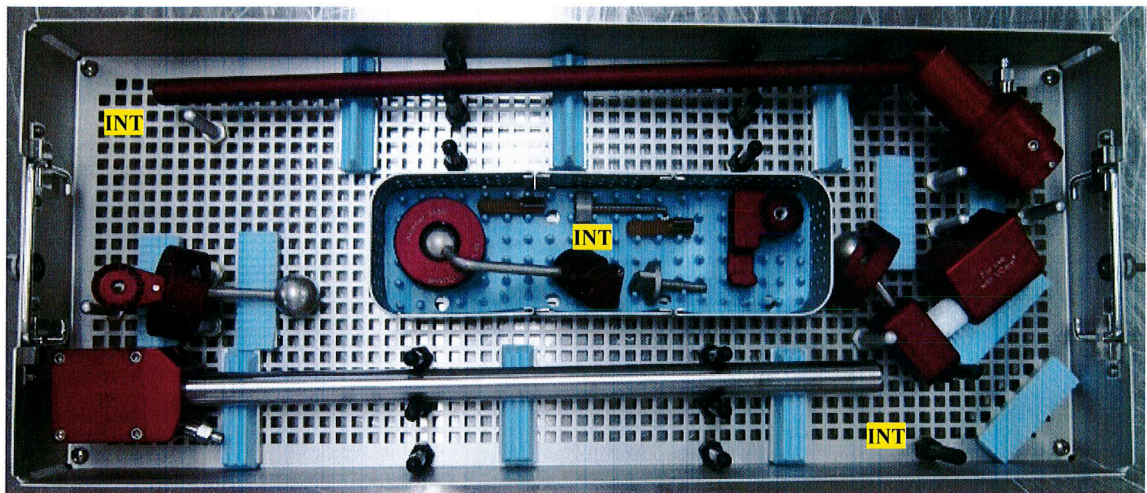

The Kronner Side-Kick A uterine manipulator Holder

Parts List for the Arch Koh instrument holder

KSK-5000 includes:

1. 5100-5150-5200 Rail grip and connector assembly
2. 5300 Main pivot assembly
3. 5700-5800 Pneumatic foot pedal and Gas supply module
4. 1120 Gas supply hose (includes one DISS fitting)
5. 5400 Outer Arm assembly
6. 5500 Inner rod with pneumatically locking ball joint

Required adapter

1. 5900 Arch Koh manipulator adapter

Replacement parts for the adapter

1. 5905 Arch Koh adapter angle adjustment screw
2. 5906 Arch Koh joining screw

Disposable components, provided sterile, (one set required for each procedure)

1. HPL1-BL1-V2 Branched gas line set, contains:
 - a. Branched line with two male luer-lock fittings on the distal end and one luer-lock female fitting with a luer activated valve on the proximal end, length: 96 inches.
 - b. Straight gas line, with one male luer-lock fitting on the distal end and one luer-lock female fitting with a luer activated valve on the proximal end, length: 96 inches.
 - c. Shelf life: 3 years

Kronner Medical

1443 Upper Cleveland Rapids Road

Roseburg, Oregon 97471

Phone: (800) 706-3533 or (541) 672-2543

Fax: (541) 672-1074

E-mail: kronner@rosenet.net